



A-eco semi-flexible luminous bollard with LEDs on top with removable plastic base in black, base specially designed for our semi-flexible A-Eco bollard with top cover folding. Simply by inserting a bollard semi-flexible inside the base, you can lock the bollard using a standard triangular key located on the side of the base to lock the lid once closed or to lock the bollard once inserted into the hole.

Bollard that offers great lighting on public roads with very low electrical cost.

Bollard ideal for lighting paths, pedestrian areas, gardens, entrances, parks, ...

STANDARD FINISHES:

Black + white leds Ref. PECOHNLB

Black + red leds Ref. PECOHNLR

+



PLASTIC REMOVABLE BASE:

Black..... BEXTRAP01

OPTIONAL:

- Double reflective strip.
- Possibility of choosing different colors of RGB LEDs.

A-ECO BOLLARDS ADVANTAGES:

-  100 % recyclable.
-  Not painted. No rust. Maintenance-free.
-  Limited flexibility.
-  High resistance to many solvents, oils and greases.
-  High resistance to abrasion.
-  Pleasant to touch.
-  Aesthetically identical to metal bollards.

MEASURES:

Diameter: \varnothing 100 mm.
View height: 885 mm.
Total height: 1100 mm.



MEASURES BASE:

Diameter: \varnothing 140 mm.
Width: 245 mm.
Height: 215 mm.

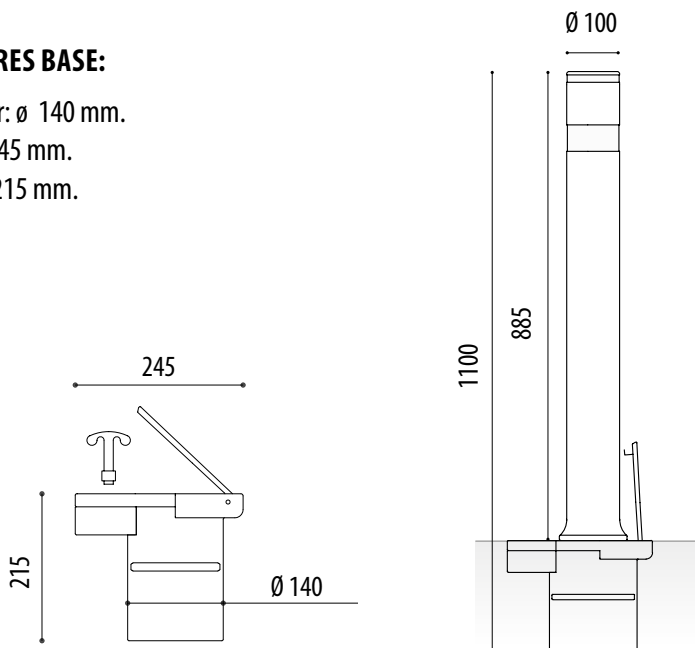



SEMIFLEXIBLE BOLLARDS

MODELO PATENTADO
PATENTED MODEL

A-ECO LED REMOVABLE



● A-ECO BOLLARDS CERTIFICATES:

1. Certificate Applus IDIADA impact-proof bollard A-Eco head (HIC).

Obtained result in test are less than <math><650</math>.
A-Eco is less than 380 (slight rating).

Applus[®]
IDIADA



2. Certificate Applus IDIADA impact-proof bollard A-Eco body (AIS).

Obtained results show a level of acceleration of the body which relates with a possibility of suffering from a damage is AIS3 of <math><10\%</math>.

Applus[®]
IDIADA



3. Certificate CE.

CE

A-Eco bollards meet the general Directive of products in the European Community according to the norm 2001/95/CE, R.D. 1803/2003.



www.adourbanfurniture.com



+34 93 116 29 75 (International) | +34 93 456 03 03 (Spanish)



info@adourbanfurniture.com