



Semi-flexible light bollard A-Eco with solar leds on top are activated automatically at dusk, led light white perimeter. Possibility of fixed light or intermittent according to the model to choose. Colored plastic removable base bollard black, base specially designed for our A-Eco semi-flexible bollard with top cover collapsible. Simply introducing a bollard flexible inside the base, the bollard can be locked using a standard triangular key located on the side of the base to lock the lid once closed or to lock the bollard once inserted in the hole.

STANDARD FINISHES:

Black + steady light **PECOHNPLSBF**

Black + flashing light..... **PECOHNPLSBI**

+

PLASTIC REMOVABLE BASE:

Black **BEXTRAP01**

OPTIONAL:

- Double reflective strip.
- Possibility of choosing different colors of RGB leds.

CARACTERÍSTICAS PILONAS A-ECO:

-  100% recyclable.
-  They are not painted. They don't rust. They do not need maintenance.
-  Limited flexibility.
-  Great resistance to oils, greases and numerous solvents.
-  Abrasion high resistance.
-  Nice touch.
-  Aesthetically identical to the metal bollards.
-  Reflective tape Level 2, improving the visibility of the pylon.

MEASURES:

Diameter: \varnothing 100 mm.
View height: 885 mm.
Total height: 1100mm.

BASIC MEASURES:

Diameter: \varnothing 140 mm.
Width: 245 mm.
Height: 215 mm.

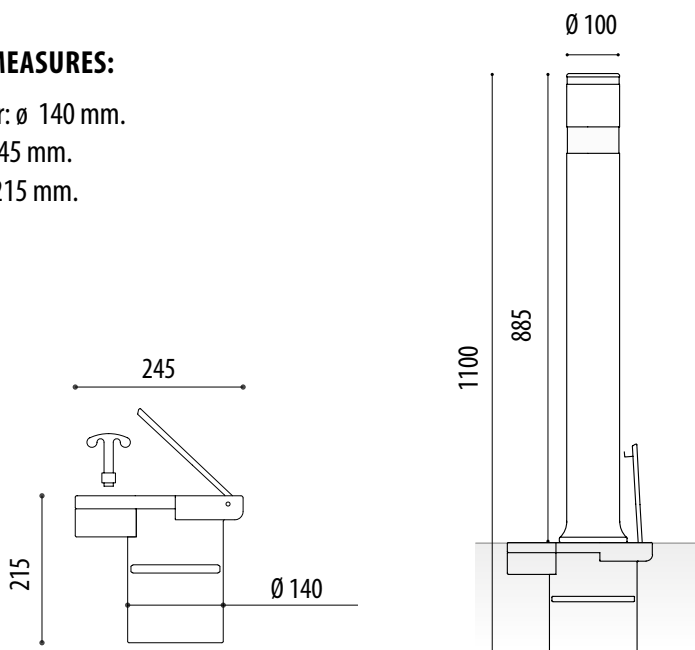



SEMIFLEXIBLE BOLLARDS

MODELO PATENTADO
PATENTED MODEL

A-ECO REMOVABLE SOLAR



CERTIFICATES A-ECO BOLLARDS:

1. Applus IDIADA certificate proof of A-Flex bollard impact on the head (HIC).



The results obtained in the test are less than < 650 .
- A-Flex is less than 216 (slight assessment).

2. Applus IDIADA certificate proof of A-Flex bollard impact on torso (AIS).



The results obtained in these tests show a level of torso acceleration that is related to a probability of suffering an AIS3 severity injury of $< 10\%$.

7. CE certificate.



The A-Flex bollards comply with the General Product Directive in the European Community according to the 2001/95/CE standard, R.D. 1803/2003.



www.adourbanfurniture.com



+34 93 116 29 75 (International) | +34 93 456 03 03 (Spanish)



info@adourbanfurniture.com