



City model luminous bollard reinforced with 2 low consumption LEDs. Constructed in a single piece avoiding the breakage of the upper part of the bollard, by means of its two lateral iron reinforcements located just above the stainless steel ring.

With the LED lighting system, a wide variety of colors is achieved: possibility of fixed or intermittent light.

STANDARD FINISHES:

Oxiron **Ref. PCITYL**
 Corten steel **Ref. PCITYCL**

OPTIONAL:

- Personalization with logo engraving.
- Reflecting tape.
- Other colors to consult.

RECOMMENDED SCREWS:

- For concrete:
 ø 11. - **Ref. T11L**



- For asphalt / panot:
 ø 10. - **Ref. T10X135**



RGB LEDs inside allowing a wide variety of colors.

MEASURES:

Diameter: ø 108 mm.
 Height: 800 mm.
 Thickness: 2,5 mm.

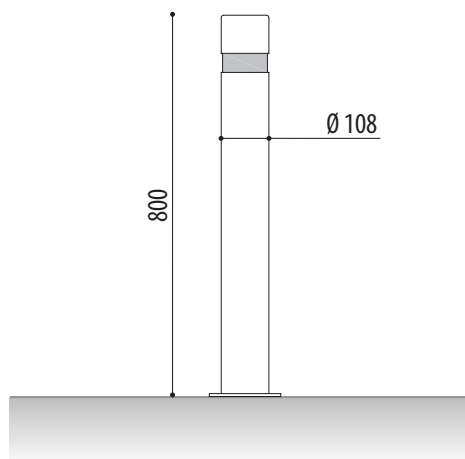



LIGHT BOLLARDS

CITY LEDS 2



ACCESSORIES:

- 1 ring for bollard. **Ref. S1AP**
- 2 rings for bollard. **Ref. S2AP**
- Galvanized chain of $\varnothing 6$ mm. **Ref. CG6100**
- 40 mm brass padlock. steel bow. **Ref. CNMCAD40**



 www.adourbanfurniture.com

 **+34 93 116 29 75** (International) | **+34 93 456 03 03** (Spanish)

 info@adourbanfurniture.com

Office, factory and warehouse: C/ Acer, 37-43 Pol. Ind. Les Guixeres 08915 Badalona - Spain