



Dogi model urban fountain in zinc-plated iron plus oven-lacquered for greater resistance to corrosion. Independent push-button taps, allowing use for people and animals.

Stainless steel drinker for the use of animals with a hole in the central part to avoid stagnant water and with a side lever to tilt the drinker.

Ideal to install in parks, gardens, schools, streets, picnics,...

MODELS:

Gray oxiron.....Ref. FDOGIG02

OPCIONAL:

- Customization with logo engraving.
- Conventional ball-type tap.
- Without bottom plate to embed (*economic range*).
- Small drops logo engraving on the front.
- Other colors to consult.



NOT INCLUDED:

- Drain grid.
- Anchor plugs.

Ref. FDOGIG02

MEASURES:

Width: 150x150 mm.
 Total height: 1000 mm.
 Inferior plate: 250x250 mm.

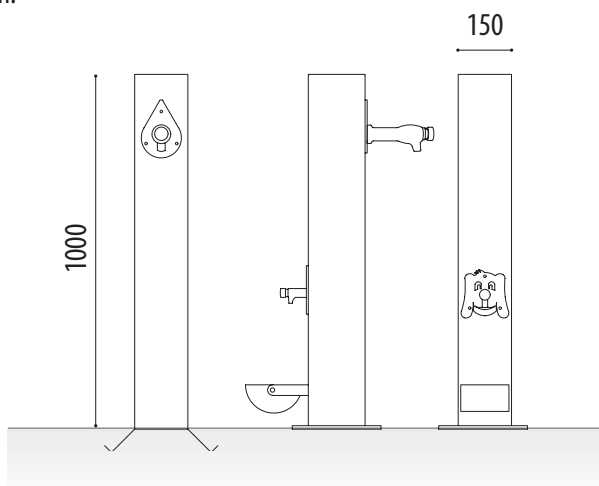

REJILLAS (OPCIONAL):

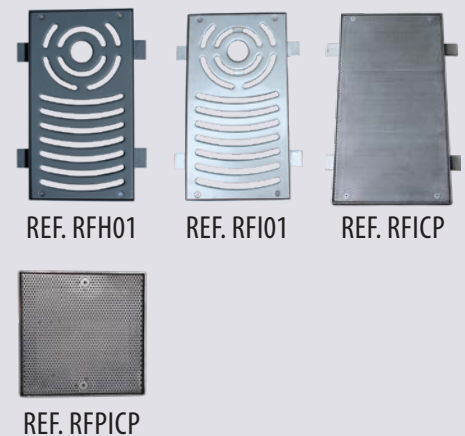



URBAN FOUNTAIN

DOGI



Detail lower tap and later emptying of the trough for animals.



www.adourbanfurniture.com

+34 93 116 29 75 (International) | +34 93 456 03 03 (Spanish)

info@adourbanfurniture.com

Office, factory and warehouse: C/ Acer, 37-43 Pol. Ind. Les Guixeres 08915 Badalona - Spain