

Cycle lane defender designed for cyclists. Its design offers great visibility and easy adaptation to all types of urban roads, thus allowing cyclists a safe circulation.

Its dimensions allow it to be installed in any kind of curved path.

FEATURES

- Recycled rubber.
- Installation in different positions.
- Vulcanized rubber.
- Installation through 3 metal screws.
- High impact resistance.
- Exceptional weather resistance.
- Designed with rounded edges without sharp corners.



TIGREVB01

TIGREVA01

MODELS

- Vulcanized white color. **TIGREVB01**
- Vulcanized yellow color. **TIGREVA01**



MEASURES

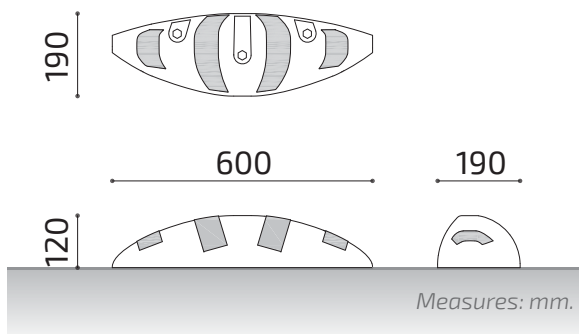



RUBBER VIAL SEPARATOR

TIGRE MODEL

INSTALLATION

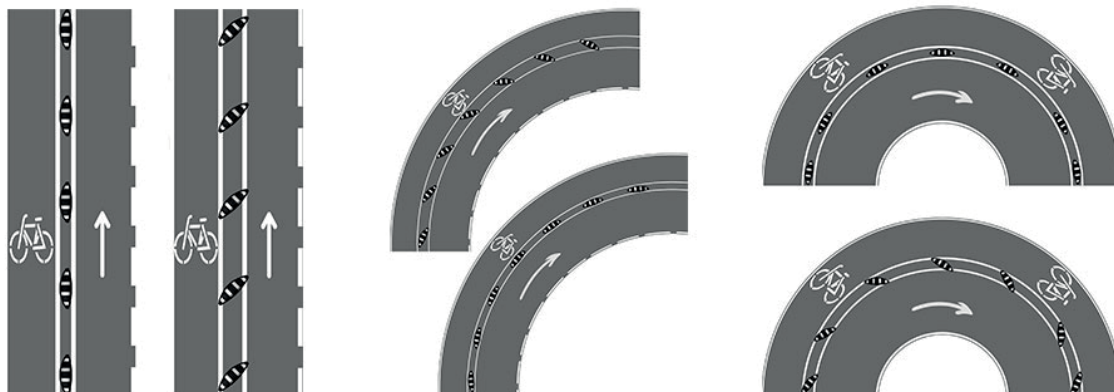

TIGRE SEPARATOR TECHNICAL CHARACTERISTICS

Elasticity modul	ref.	5,0 - 12,0 Mpa 5,0 minium	UNE EN ISO 527-2527-2 UNE-ISO 37:2013	>10 Mpa 6,365 Mpa
Elongation at break	ref.	130-142% 100% minium	ISO527.25272/UNE12803.2001 UNE-EN 37:2013	>120 113%
Tear resistance		8,5 - 36 kN/m 15 Kn/m minium	UNE-ISO 34-A:2011	20,45 Kn/m
Hardness	ref.	ShA 81-85 85 ± 5	UNE ISO868.98/DUV UNE-ISO 868:2003	>80 87
Recyclability	ref.	S/N S/N	100% 100%	
Abrasion loss	ref.	163 mm3 - 109 mg/1000 cicles 250 mm3 max.	UNE 135203	mg/1000 cicles 170 mm3
Anchors number	ref.			3 unt 3 unt
Useful life under normal conditions	ref.			10 years 10 years
Useful life under normal conditions	ref.		PI0023SAM	200 kn >11767 kn
Density			UNE-ISO 2781:2015	1,20 gr/cm3 ± 0,05
Anchor joint resistance			PI0026 SAM	>150 kg/cm2



www.adourbanfurniture.com

+34 93 116 29 75 (International) | +34 93 456 03 03 (Spanish)

info@adourbanfurniture.com