

ADO
design



Ref. FUTRIAN02

Trian model design urban fountain. Lacquered iron or corten steel structure with front sheet in satin stainless steel to prevent possible corrosion.

Designed with round edges to avoid possible damage to people.

Ideal to install in parks, schools, gardens, streets, ...

STANDARD FINISHES:

Corten steel Ref. FUTRIAN02

OPTIONAL:

- Customization with logo engraving.
- Conventional ball-type tap.
- Without bottom plate to embed (*economic range*).
- Small drops logo engraving on the front.
- Other colors to consult.



NOT INCLUDED:

- Drain grid.
- Anchor plugs.

MEASURES:

Width: 200x200 mm.
Height: 1000 mm.

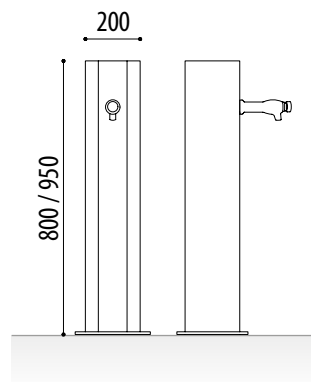

GRIDS (OPTIONAL):

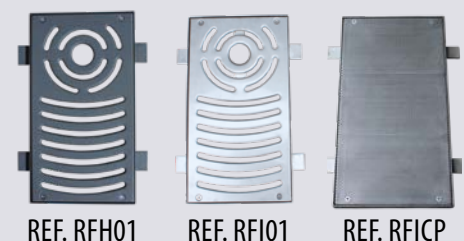

REF. RFH01

REF. RFI01

REF. RFICP