



**Victoria urban drinking fountain with elaborate design.** Structure available in lacquered, weathering or stainless steel, inner sheet in stainless steel. Push button tap.

Stainless steel drain grate included. Ideal installation in parks, schools, gardens, and streets.

### STANDARD FINISHES:

900x950 mm.:

Stainless steel ..... Ref. FVICT001II

900x800 mm.:

Stainless steel ..... Ref. FVICT003II



### Advantages:

- Urban drinking fountain suitable for disabled people. 
- Tap with anti-rotation safety push button.
- Upper lateral opening of the fountain to easily access the tap without disassembling the fountain.

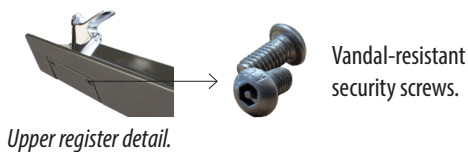

- See different options to supply our drinking fountains with further advantages.

### Optional:

- Possible addition of a dog drinker.



- Possible addition of a lateral opening at the bottom of the fountain.

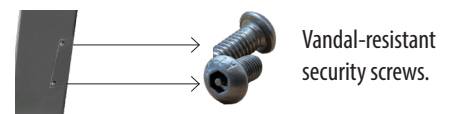

- Customisation with the Municipality logo or coat of arms.





# OUTDOOR FOUNTAIN

## VICTORIA

### SIZE:

Width: 210 mm.

Visual height: 800 / 950 mm.

Total height: 950 / 1100 mm.

Length: 900 mm.

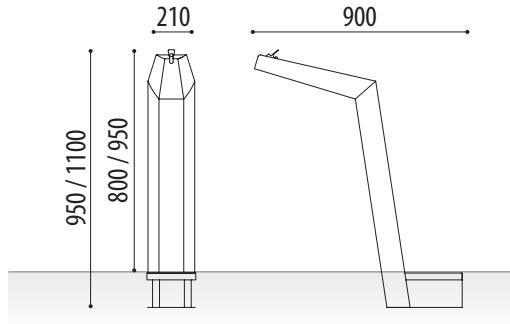

### Grates

A screwable drain grate is included with security screws to avoid theft

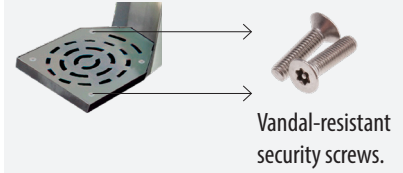

 [www.adourbanfurniture.com](http://www.adourbanfurniture.com)

 +34 93 116 29 75 (International) | +34 93 456 03 03 (Spanish)

 [info@adourbanfurniture.com](mailto:info@adourbanfurniture.com)